

Information about the author

Ya. Kononenko – postgraduate student of Economics of an Enterprise Department of Kharkiv Humanities University "National Ukrainian Academy" (27 Lermontovska St, 61024, Kharkiv, e-mail: yana.kononenko@gmail.com).

Інформація про автора

Кононенко Яна Володимирівна – здобувач кафедри економіки підприємства Харківського гуманітарного університету "Народна українська академія" (61024, м. Харків, вул. Лермонтовська, 27, e-mail: yana.kononenko@gmail.com).

Информация об авторе

Кононенко Яна Владимировна – соискатель кафедры экономики предприятия Харьковского гуманитарного университета "Народная украинская академия" (61024, г. Харьков, ул. Лермонтовская, 27, e-mail: yana.kononenko@gmail.com).

*A double-blind
peer review has been held.*

*Стаття надійшла до ред.
28.11.2012 р.*

MODELING OF CUSTOMER SERVICE IN DRUGSTORES

UDC 330.4

O. Dorokhov

The opportunity and necessity of imitating modeling applications for improvement of customer service quality at purchase of drugs and medical products in retail pharmacy establishments are proved. The corresponding conceptual base model for service of drugstore's visitors at purchase of drugs by them has been developed. The statement of this task in view of specificity of retail trade by pharmaceutical production is presented. On the basis of imitating modeling and special software the main model is constructed. Its step-by-step development is consistently presented. Methodological approaches to interpretation of modeling results and directions of their practical usage for improvement of pharmaceutical service quality and work of drugstores are offered. Implementation of described models in the ExtendSim7LT environment for simulation has been executed.

Key words: queuing system, drugstores, imitating modeling, computer simulation.

МОДЕЛЮВАННЯ ОБСЛУГОВУВАННЯ КЛІЄНТІВ В АПТЕКАХ

УДК 330.4

Дорохов О. В.

Розглянуто можливості моделювання системи масового обслуговування для поліпшення організації роздрібного продажу ліків в аптеках. Обґрунтовано можливість і необхідність застосування імітаційного моделювання для поліпшення логістичного обслуговування покупців і підвищення якості послуг. Розроблено відповідний підхід і обрано інструменти моделювання. Завдання розглянуто з урахуванням специфіки роздрібної торгівлі фармацевтичною продукцією. На основі імітаційного моделювання та спеціального програмного забезпечення побудовані й послідовно представлені моделі, що мають практичне значення. Запропоновано підходи до

інтерпретації результатів моделювання та можливі напрями практичного використання цих результатів для вдосконалення якості фармацевтичного обслуговування і роботи аптек. Виконано комп'ютерну реалізацію розроблених моделей у середовищі моделювання ExtendSim для різних практичних умов обслуговування.

Ключові слова: система масового обслуговування, аптеки, імітаційне моделювання, комп'ютерна симуляція.

МОДЕЛИРОВАНИЕ ОБСЛУЖИВАНИЯ КЛИЕНТОВ В АПТЕКАХ

УДК 330.4

Дорохов А. В.

Рассмотрены возможности моделирования системы массового обслуживания для улучшения организации розничной продажи лекарств в аптеках. Обоснованы возможность и необходимость применения имитационного моделирования для улучшения логистического обслуживания покупателей и повышения качества услуг. Разработан соответствующий подход и выбраны инструменты моделирования. Задача рассмотрена с учетом специфики розничной торговли фармацевтической продукцией. На основе имитационного моделирования и специального программного обеспечения построены и последовательно представлены модели, имеющие практическое значение. Предложены подходы к интерпретации результатов моделирования и возможные направления практического использования этих результатов для совершенствования качества фармацевтического обслуживания и работы аптек. Выполнена компьютерная реализация разработанных моделей в среде моделирования ExtendSim для различных практических условий обслуживания.

Ключевые слова: система массового обслуживания, аптеки, имитационное моделирование, компьютерная симуляция.

Under the condition of the financial crisis the competition, fight for the market in all spheres of commerce and produce arises. This is also applicable to the Ukrainian pharmacy market and the system of retail sale of medical goods. However, an essential part of the improvement of pharmaceutical service in drugstores is the appropriate organization of selling the drugs, medicines and medical goods.

Improving the Ukrainian citizen's pharmacy supplying according to difficult social, economic, ecological and demographical situation in the state became an important and actual goal. Organization of appropriate pharmaceutical service in the drugstores became an essential component of its solving.

Drugstores have to provide appropriate quality services for customers. It contains not only production assortment and costs parameters. It must be qualitative by time parameters, efficiency and services comfort.

The analysis of the literature sources showed that the issues and problems of evaluating the performance of companies in general, were mentioned in many of publications of Ukrainian economists.

Among them are scientific research works of some well-known authors such as V. S. Ponomarenko, T. S. Klebanova, T. I. Lepeyko, P. A. Orlov and others [1 – 4].

Different approaches and tools of mathematical modeling of the various economic problems are well represented in the papers and works of N. A. Kizim [5], J. G. Bersutsky, N. N. Lepa, T. S. Klebanova [5 – 8].

In fundamental research by T. V. Merkulova different modeling methods, in particular – simulation, multi-agent system's approach, ABS analysis were discussed in detail [9 – 13]. Queuing systems and their role in modeling of economic and production processes have been working consistently and in detail in the publications of N. V. Ruyantsev [14 – 17].

However, despite all of the above mentioned, the simulation of queuing systems in specific production areas is not enough represented in the literature.

Also the results of corresponding computer simulations in specialized program's tools and packages were not properly described. Those are practically absent, for example, for queuing systems in the service sector (trade, transport, passenger services, the pharmaceutical retail market, etc.).

The problem of final drugstore consumers' services improvement takes an important place in the scientific researches and corresponding publications [18 – 21]. The author identifies some major researching methods.

First of all, there are marketing solutions – target market choice, production assortment and services set management, pricing policy and selling simulation providing, definition of entrepreneurship, location etc.

Such problem as staff management is also important (in particular, upgrading of its qualification level, competence, professional level and labor potential). If we mean directly customers, factors of drugstore services culture (in its wide sense: politeness, pleasant attitude from the side of drugstore staff, high servicing speed, minimization of waiting time etc.) is a powerful factor.

Selling customers medicines is a process of queuing service with its basic and specific elements which reflect the features of organization of selling pharmaceutical production [18 – 21].

Computer modeling of such a system will lead to the minimization of the time of consumers' service and queue, optimization of the work of pharmacists, and etc. So, intensive research of such systems of mass medicine service in the drugstores is necessary [22 – 24]. Also the development of the discrete simulation models in the computer modeling tools [25, 26] and the analysis of the results and recommendation of medicine selling are in great demand.

From the point of view of modeling abilities and means it is rational to consider the process of drugstore visitors servicing while buying drugs and production for medical purposes as a mass services system with characteristic general and specific (which show the features of pharmaceutical services) components.

The development and research of such a system (speaking in particular about drugstore entrepreneurship) gives an ability of definition and optimization of such important characteristics as transactions servicing time, existence and parameters of queues, servicing devices congestion etc.

Accordingly, the modeling of consumer buying process in a drugstore by the means of queuing service theory is defined as a research goal.

It is provided to develop corresponding computer model with the next analysis of received results and producing the recommendations for practical improving of consumers services in drugstores.

It is known that the general methodological goal of mathematics modeling is creating an environment, which gives an ability to get appropriate information about sides and characteristics of modeling object using the calculated experiment without direct contact with this object [22 – 24].

In particular, imitating modeling (including queues modeling in mass services systems like drugstores) allows to get quantitative characteristics of expecting commercial-management solutions for their next optimization.

This solution during the separate imitation can take different concrete meanings as a result of probability nature of some (or all) model input parameters. That's why imitating modeling provides carrying out of multiple tests (calculations) of model. That gives an ability of fast identification of statistically authentic and mathematically proved numerical meanings for the researched services parameters.

The necessity of customers services optimization during direct drugs purchase arises, because costs of staff maintenance and customers services permanently increase, also because the quantity of drugstore entrepreneurship rises and competitive struggle for each customer aggravates.

From the other side, in competitive market conditions there is a necessity of rational, economically proved and rental organization of pharmacists' work, considering norms of labor right, professional and branch standards, which are regulated by trade-unions requirements etc.

There are some demands for models, which can analyze such factors influencing the quality and economic consequences of consumers services as: probability characteristics of consumers' occurrence, terms of their servicing by pharmacists, consumers' behavior if there is a queue or servicing delays, presence of additional consultation medical service (for example, doctor's consultation). It is important to note, that choice of imitating modeling as an instrument of queues research is defined by the following conditions.

First, analogical analytical models often become very difficult for formation and analysis, sometimes it is impossible to build them. A lot of probability factors are considerably complicated to creating such kind of models.

Secondly, quite often analytical models give average-statistics or stationary, long-term solutions. In practice, though, non-stationary behavior of a system or its characteristics on a short time interval are important. This doesn't give an ability to get and to use average-statistics meanings.

Thirdly, a large set of specialized software has been developed and published nowadays for the needs of imitating modeling. At the same time, the necessary level of user's computer and mathematical proficiency has considerably lowered; this allows developing, researching and practical introducing of imitating models by managers or decision-making persons at pharmaceutical entrepreneurship.

Taking into account the written above, today imitating models are often being developed instead of analytical ones which give operative and authentic definition of real complex systems parameters such as system of drugs distribution and its subsystem of customer's services in the drugstore.

In order to identify the initial parameters of the model the pilot surveillance was conducted. A number of indices were fixed: the time when the customer enters the drugstore, the number of counters, the duration of service by the pharmacists, the amount of the purchase. The subsequent return of the customers to the counter, the case when the customer left the queue because of its length and etc. were also taken into account.

The analysis of initial parameters was conducted in the Statistic program. For the time lines of the customers' entrance, the duration of staying in the queue, the amount of the purchase the hypotheses of normal, exponential and extreme dispersions were proved (corresponding examples are shown in Fig. 1 and 2).

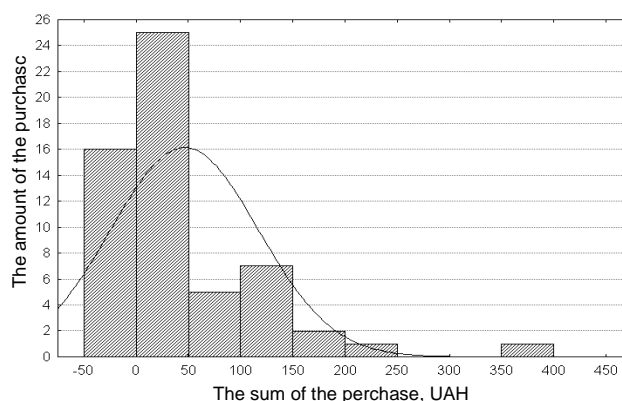

Fig. 1. The dispersion for amount of purchase (hryvnia)

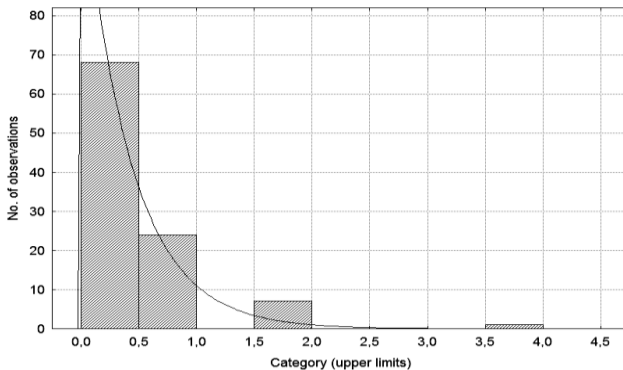

Fig. 2. The dispersion for duration of staying in queue (min)

Let us consider the drugstore consumers services system model in the next statement. The customers enter the drugstore during time intervals, which are defined by some statistical distribution, installed by the results of real supervision in a drugstore.

Servicing (drugs sales) is organized by some sellers-pharmacists (in drugstore windows). Each of pharmacists spends some time for the servicing of one customer. This time is also given by statistical distribution, defined by chronometrical supervision. All windows work during 10 hours (full) without breaks or pauses. If a new visitor enters and all the windows are occupied, he (or she) appears at the end of a common queue, then moves ahead it until some window will be free and this customer will be serviced.

At the beginning of a working day there are no visitors in the drugstore. When a drugstore's work ends, customers in the queue won't be serviced. Only servicing of customers, which are directly near the windows, is completely done. The purpose of the model is to imitate drugstore's work, in particular the existence and statistics of queues during some period of time. As a result of statistical data main characteristics of drugstore customer service are defined: average and maximal time of their waiting in the queue; average and maximal queue length; quantity of customers, which have been serviced, pharmacists work load; share of customers, which haven't been serviced. Graphical view of corresponding computer model is shown in the Fig. 3. The model consists of some main blocks:

- No. 1 – input of time and some other parameters of imitation modeling;
- No. 2 – entrance of visitors to a drugstore;
- No. 3 – common queue of customers;
- No. 4 – servicing window No. 1;
- No. 5 – servicing window No. 2;
- No. 6 – servicing window No. 3;
- No. 7 – exit from drugstore;
- No. 8 – input of service's parameters for window No. 1;
- No. 9 – input of service's parameters for window No. 2;
- No. 10 – input of service's parameters for window No. 3;
- No. 11 – result information about work of servicing windows (for one imitation);
- No. 12 – output of resulting information about queue (for one imitation);
- No. 13 – output of total summary results for all imitations (for windows);
- No. 14 – output of total summary results for all imitations (for queues).

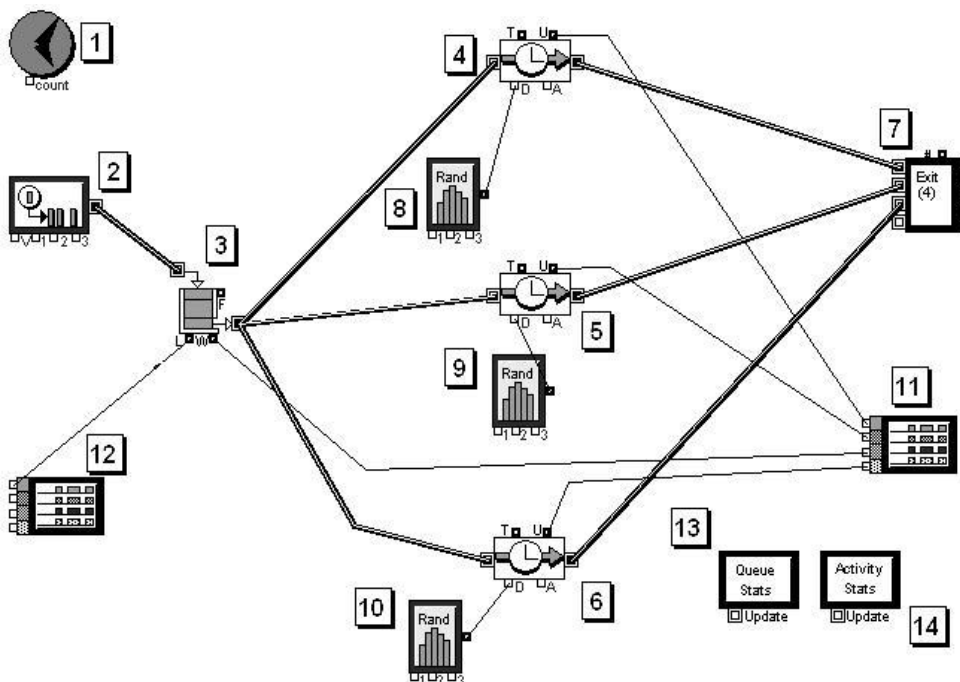

Fig. 3. Imitational model of customer's queue servicing at the drugstore

This model allows the user to change the next entering parameters (in brackets measure units are written):

- time measurement units (minutes);
- drugstore working hours (10 hours);
- frequency of customers appearance, its probability character depending on different distributions (triangular distribution with the most expected appearance of the next customer in 3 minutes);
- quantity of servicing windows (one, two or three windows);
- duration of one customer servicing in some window (triangular distribution, individual for each window, with an average servicing time 4, 5 and 6 minutes for windows No. 1, No. 2 and No. 3 correspondently).

Entrance parameters for the model shown in Fig. 3 for distributions of customer's appearance and one client servicing terms in each window are shown in Table 1.

Table 1

Customers appearance and servicing distributions, min

Time	Customer's entrance	Servicing time		
		Window No. 1	Window No. 2	Window No. 3
Minimum	1	2	3	5
Most probable	2	10	6	8
Maximum	5	12	9	12

The imitation was conducted when only one, two or all three windows were working at the same time. Modeling results, in particular queue characteristics – length and waiting time, windows loading for 50 model imitations with 95% confidential interval are shown in Table 2. The results of some imitations may be received in the graphical view using the special model blocks.

By using modeling results analysis one can make a conclusion that drugs selling in three windows is the most optimal (also from the point of view of customers servicing quality and pharmacists loading), if this number of windows, total queue to all of them on the average is absent and doesn't exceed 4 customers. Waiting time in the queue is on the average 1.5 minutes and doesn't exceed 7 minutes. Such a service is entirely acceptable for the customers. From the other side, the pharmacists are loaded by the work for 90 – 95 % of working hours, what is quite high, practically maximal parameter of their use efficiency.

Though, the reduction of windows quantity would provide very long queues and long waiting time for customers. Windows quantity increase would provide stagnation of drugstore staff.

The author has developed this model taking into account some important additional factors. For example, the next situation is provided, when a long queue or long waiting time the customer leaves the drugstore. Also repeated turning of a customer after the first purchase is provided.

Table 2

Modeling results with 95 % reliability (simulation duration time is 600 minutes)

Servicing parameters	Only window No. 1 works	Windows No. 1 and No. 2 work	All three windows work
Average queue length	76	24	0
Maximal queue length	151	49	4
Average waiting time	199	64	1.4
Maximal waiting time	400	131	7.5
Total customers serviced	71	185	227
Serviced in window No. 1	71	81	69
Loading of window No. 1	100 %	100 %	94 %
Serviced in window No. 2	-	104	94
Loading of window No. 2	-	99 %	89 %
Serviced in window No. 3	-	-	64
Loading of window No. 3	-	-	88 %

Extraordinary occasion describes the existence of consulting services in the drugstore, for example when some visitors are being consulted by the doctor.

The author has also researched the optimal windows quantity using comparing of its functioning costs and potential losses because of customers exit in case of long queue and long waiting time. Corresponding models are developed and would be presented in the next part of the paper.

The first step to create discrete simulation models is shown in Fig.4. This model includes the following items:

- No. 1 – input model parameters;
- No. 2 – customers' entry to the drugstore;
- No. 3 – joint queue;
- No. 4 till No. 6 – servicing windows (drug's sale);
- No. 7 – drugstore exit and statistics summary collection;
- No. 8 till No. 10 – time of service for each window;
- No. 11 till No. 14 – service time representation of results for multi-time runs;
- No. 15 and No. 16 – representation of the number of work items that have exceeded their waiting limit;
- No. 17 – analysis of the queue;
- No. 18 – counting the work items that have left the drugstore at once.

Additional units represent other features of the model:

- No. 19 till No. 21 – count repeated service;
- No. 22 till No. 24 – the formation of the joint queue and clients' return to the common entry queue;
- No. 25 till No. 27 – reflect the repeated service of different customers at each cash desk.

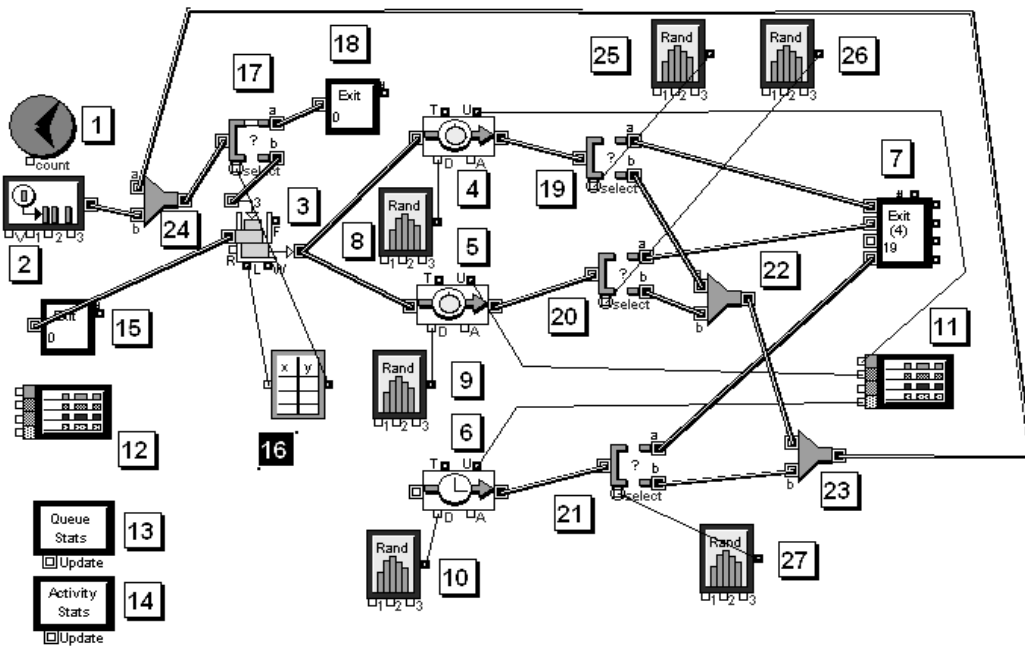

Fig. 4. The model with three servicing devices, analyses of the length of the queue and the time of waiting, returning of the customers to the common entrance queue for repeated service

This base model allows the user to change the next entering parameters (in brackets measure units are written): time measure units (minutes); drugstores working time (hours); frequency of customer's appearance, its probability character depending on different distributions; quantity of servicing windows (one, two, three windows); duration of one customer servicing in a window.

In further models the presence of a doctor in the drugstore, customers, priorities different cash desks in case of

epidemics and etc must be taken into account. It is necessary for the ultimate imitation modeling for different groups of drugstores according to the models that reflect the practical organization of selling drugs in them.

In order to compare, one should consider a drugstore with two servicing windows. The first model assumed the single queue to all windows. A case with separate queues is presented in Fig. 5.

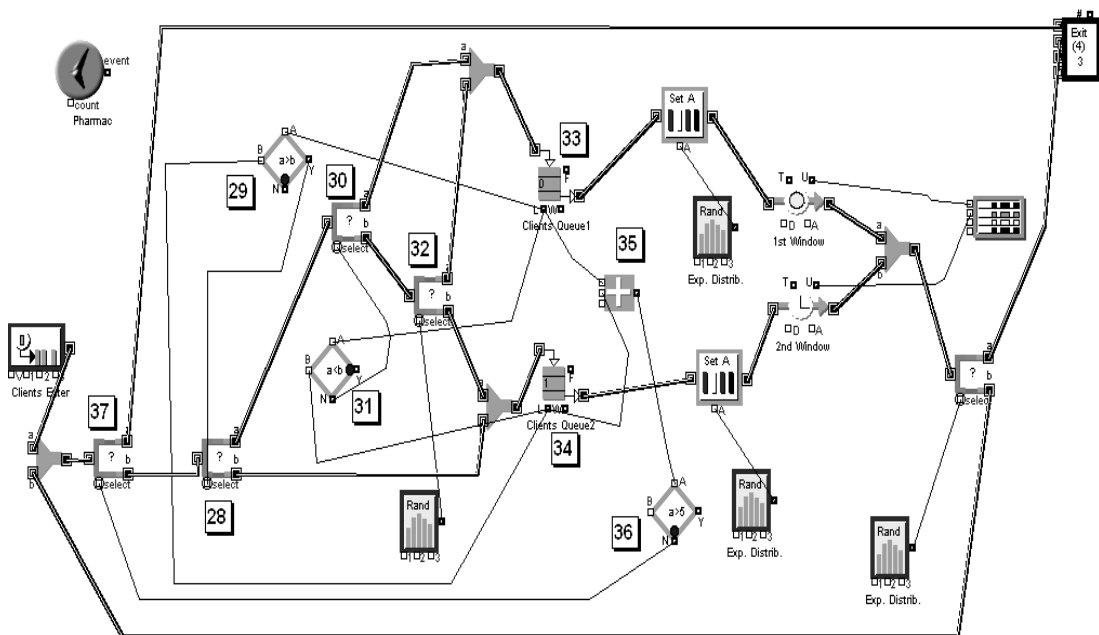

Fig. 5. The model with two servicing windows and separate queues to them, with clients leaving if common queue is unacceptable

The client goes to a window with smaller queue.

If queues are identical, the buyer joins any. If the total number of buyers in both queues exceeds admissible, a new client leaves a drugstore.

This model contains the next additional blocks:

No. 28, 30 and No. 32 – choice of clients way to smaller queue, where the number of clients is less;

No. 29 and No. 31 – blocks for comparison of queues length;

No. 33 and No. 34 – separate queues before the first and the second servicing windows;

No. 35 – summary of common number of clients in both queues;

No. 36 and No. 37 – blocks which provide clients' leaving the drugstore if common queue length is unacceptable.

The next step for the models is presented in Fig. 6.

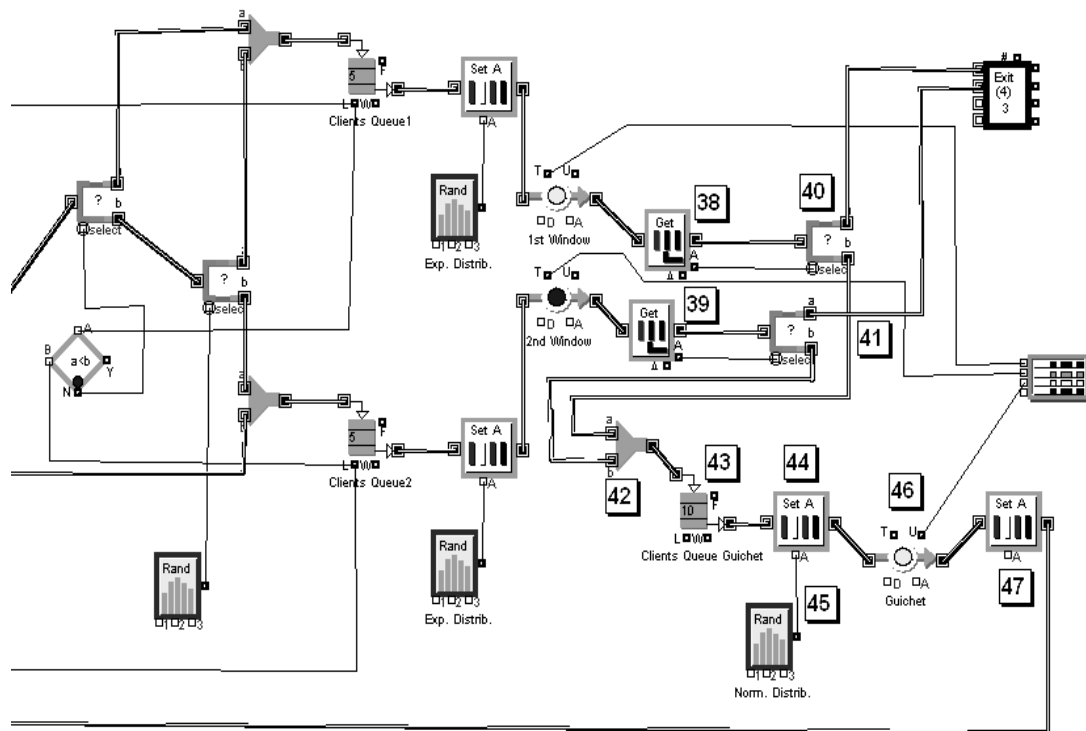

Fig. 6. The model with two servicing windows and separate cash (pay) window

In this case the buyer after the choice of drugs in servicing window (at the pharmacist) pays its cost in a separate cash window, and then again comes back do the single queue to get the paid purchase at the pharmacist. For this purposes corresponding group of block was added to finish the previous model:

No. 38 and No. 39 – the removal of the attribute, which confirms the provided service of the buyer in cash window (payment of drugs by him);

No. 40 and No. 41 – the checking of conditions (if payment is needed then a client goes to cash window, and drugs are already taken by buyer and he leaves);

No. 42 – the formation of the single queue from two service windows before cash window;

No. 43 – the queue before cash window;

No. 44 and No. 45 – servicing time parameters for cash window;

No. 46 – cash (pay) window;

No. 47 – block for the set, which confirms the payment in cash window and the subsequent clients transition to initial model (common input and formation of queues for both servicing windows).

Other blocks are necessary to be included in the model for priority buyers occurrence. Corresponding model is shown in Fig. 7.

There are such new fragments:

No. 48 – priority distribution;

No. 49 – block of priorities selection;

No. 50 and No. 51 – sets for different priorities;

No. 52 and No. 53 – queues before servicing windows with analysis of buyers' priorities.

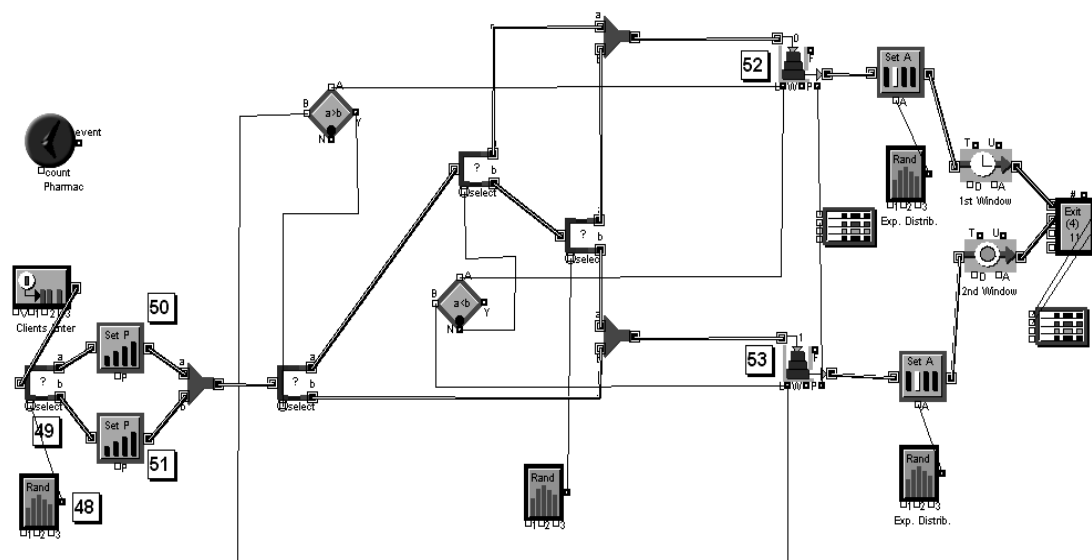

Fig. 7. The model with priority clients

The author has developed the described models considering other factors. For example, the next situations were provided, when a long queue or long waiting time made the customer leave the drugstore.

Also repeated returning of a customer after the first purchase has been provided. Extraordinary occasion describes the existence of consulting services in the drugstore, for example when some visitors are being consulted by the doctor. And also the abilities of optimal windows quantity defining using the comparison of its functioning costs and potential losses because of customers exit in case of long queue and waiting time were researched.

Thus, the productive approach to imitating modeling for queues in drugstores and customers services have been developed and presented. The developed computer models in ExtendSim7LT environment allow to get important characteristics of pharmaceutical services using statistical data and calculation experiment – existence of queues, waiting time, pharmacists loading etc.

The presented model developments enable us to demonstrate and to formalize the process of drugstore visitors servicing, to identify the main directions of drugstore's work improvement taking into account interests of customers and the pharmaceutical entrepreneurship, to make proved economic and mathematical calculations of different possible variants of servicing and staff functioning organization. As a result it is possible to improve the customer's service and to optimize functioning of the drugstores. After the calculative experiments it appeared that the developed models give a chance to improve the quality of service and at the same time to optimize the work of pharmacies on the basis of computer modeling and the analysis of different ways of selling medicines.

References: 1. Пономаренко В. С. Проблема оцінки системної ефективності функціонування та розвитку підприємства / В. С. Пономаренко, І. В. Гонтарева // *Економіка розвитку*. – 2011. – № 1(57). – С. 5–8. 2. Орлов П. А. Проблемы управления качеством продукции и повышения социальной ответственности предприятий / П. А. Орлов // *Економіка розвитку*. – 2011. –

№ 1(57). – С. 8–13. 3. Лепейко Т. І. Організаційна перебудова персоналу підприємства як складова процесу реструктуризації / Т. І. Лепейко, Н. К. Назаров // *Економіка розвитку*. – 2011. – № 1(57). – С. 13–15. 4. Клебанова Т. С. Моделі моніторингу внутрішнього середовища промислового підприємства / Т. С. Клебанова, К. С. Коваленко // *Бізнес Інформ*. – 2011. – № 5(2). – С. 13–17. 5. Адаптивные модели в системах принятия решений: монография / под ред. Н. А. Кизима, Т. С. Клебановой. – Х. : ИД "ИНЖЭК", 2007. – 368 с. 6. Принятие решений в управлении экономическими объектами: методы и модели: монография / Я. Г. Берсуцкий, Н. Н. Лепа, Т. С. Клебанова и др. – Донецк : Изд. ТОВ "Юго-Восток", ЛТД, 2000. – 276 с. 7. Сучасні та перспективні методи і моделі управління в економіці: монография / Т. С. Клебанова, Л. С. Гурьянова, О. М. Беседовський та ін.; під ред. д. е. н, проф. А. О. Спіфанова. – Суми : ДВНЗ "УАБС НБУ", 2008. – 315 с. 8. Современные проблемы моделирования социально-экономических систем: монография / Т. С. Клебанова и др. – Х. : ИД "ИНЖЭК", 2009. – 440 с. 9. Меркулова Т. В. Использование имитационного моделирования в налоговом менеджменте / Т. В. Меркулова, С. Н. Костенко // *Вісник ХНУ імені В. Н. Каразіна. Економічна серія*. – 2009. – № 892. – С. 163–169. 10. Меркулова Т. В. Мультиагентный подход к моделированию экономической системы в условиях нестационарной внешней среды / Т. В. Меркулова, Н. В. Акулов // *Бізнес Інформ*. – 2009. – № 4(2). – С. 114–117. 11. Меркулова Т. В. Математические модели в автоматизации управления запасами / Т. В. Меркулова, Н. В. Акулов // *Економіка: проблеми теорії та практики: зб. наук. пр.* – Дніпропетровськ : ДНУ, 2007. – Вип. 232. – Т. II. – С. 525–533. 12. Меркулова Т. В. Использование АВС-анализа в управлении запасами / Т. В. Меркулова, Н. В. Акулов // *Вісник ХНУ імені В. Н. Каразіна. Економічна серія*. – 2007. – № 786. – С. 140–143. 13. Меркулова Т. В. Критерии оценки деятельности налоговой службы в свете теории агентских отношений / Т. В. Меркулова // *Наукові праці Донецького національного технічного університету. Серія: економічна*. – Донецьк : ДонНТУ, 2008. – Вип. 34-2(138). – С. 174–178. 14. Румянцев Н. В. Моделирование гибких производственно-логистических систем / Н. В. Румянцев. – Донецк : Изд. "Юго-Восток", 2004. – 235 с. 15. Румянцев М. В. Дослідження системи обслуговування з ненадійним приладом і переналагодженням на початку періоду зайнятості / М. В. Румянцев // *Бізнес Інформ*. – 2011. – № 7. –

С. 10–13. 16. Румянцев М. В. Гнучкі логістичні системи з переналагодженням на початку періоду зайнятості й втратою вимог / М. В. Румянцев // Бізнес Інформ. – 2012. – № 4. – С. 25–27. 17. Румянцев М. В. Гнучкі логістичні системи з переналагодженням в кінці періоду зайнятості та втратою вимог / М. В. Румянцев // Бізнес Інформ. – 2012. – № 5. – С. 51–54. 18. Мнушко З. М. Аналіз напрямків досліджень з економіки, менеджменту та маркетингу в фармації / З. М. Мнушко // Вісник фармації. – 2004. – № 4. – С. 53–58. 19. Громовик Б. П. Проблемні питання логістичного обслуговування споживачів лікарських засобів / Б. П. Громовик // Фармацевтичний журнал. – 2007. – № 5. – С. 14–18. 20. Пестун І. В. Маркетингове інформаційне забезпечення процесу прийняття управлінських рішень в фармації / І. В. Пестун, З. М. Мнушко // Фармацевтичний журнал. – 2007. – № 1. – С. 9–14. 21. Толочко В. М. Управління фармацією / В. М. Толочко. – Х. : Вид. НФаУ, 2004. – 386 с. 22. Дорохова Л. П. Модель в менеджменті. Фармацевтична енциклопедія / Л. П. Дорохова. – К. : Моріон, 2005. – С. 519–520. 23. Довгань С. В. Математичне моделювання в маркетингу / С. В. Довгань. – Дніпропетровськ : НГУ, 2002. – 194 с. 24. Шеннон Р. Имитационное моделирование систем – искусство и наука / Р. Шеннон. – М. : Мир, 1978. – 301 с. 25. Modeling of two strategies in inventory control system with random lead time and demand / Е. Копытов, L. Greenglaz, A. Muravyov et al. // Computer Modeling and New Technologies. 2007. – No. 1. – Pp. 21–30. 26. Moore J. Decision modeling with Microsoft Excel / J. Moore, L. Weatherford. – New Jersey : Prentice Hall, 2004. – 1 024 p.

References: 1. Ponomarenko V. S. Problema otsinky systemnoi efektyvnosti funktsionuvannya ta rozvytku pidpriemstva / V. S. Ponomarenko, I. V. Hontareva // Ekonomika rozvytku. – 2011. – No. 1(57). – Pp. 5–8. 2. Orlov P. A. Problemy upravleniya kachestvom produktii i povysheniya sotsialnoyi otvetstvennosti predpriyatiy / P. A. Orlov // Ekonomika rozvytku. – 2011. – No. 1(57). – Pp. 8–13. 3. Lepeiko T. I. Orhanizatsiina perebudova personalu pidpriemstva yak skladova protsesu restrukturyzatsii / T. I. Lepeiko, N. K. Nazarov // Ekonomika rozvytku. – 2011. – No. 1(57). – Pp. 13–15. 4. Klebanova T. S. Modeli monitorynhu vnutrishnioho seredovyscha promyslovoho pidpriemstva / T. S. Klebanova, K. S. Kovalenko // Biznes Inform. – 2011. – No. 5(2). – Pp. 13–17. 5. Adaptivnyye modeli v sistemakh prinyatiya resheniy : monografiya / pod red. N. A. Kizima, T. S. Klebanovoy. – Kh. : ID "INZhEK", 2007. – 368 p. 6. Prinyatiye resheniy v upravlenii ekonomicheskimi obyektami: metody i modeli : monografiya / Ya. G. Bersutskiy, N. N. Lepa, T. S. Klebanova i dr. – Donetsk : Izd. TOV "Yugo-Vostok", LTD, 2000. – 276 p. 7. Suchasni ta perspektivni metody i modeli upravlinnia v economitsi : monografiya / T. S. Klebanova, L. S. Hurianova, O. M. Besedovskiy ta in. ; pid red. d. e. n., prof. A. O. Yepifanova. – Sumy : DVNZ "UABS NBU", 2008. – 315 p. 8. Sovremennyye problemy modelirovaniya sotsialno-ekonomicheskikh sistem : monografiya / T. S. Klebanova i dr. – Kh. : ID "INZhEK", 2009. – 440 p. 9. Merkulova T. V. Ispolzovanie imitatsionnogo modelirovaniya v nalogovom menedzhmente / T. V. Merkulova, S. N. Kostenko // Visnyk KhNU imeni V. N. Karazina. Ekonomichna seriia. – 2009. – No. 892. – Pp. 163–169. 10. Merkulova T. V. Multiagentnyy podkhod k modelirovaniyu ekonomicheskoy sistemy v usloviyakh nestatsionarnoy vneshney sredy / T. V. Merkulova, N. V. Akulov // Biznes Inform. – 2009. – No. 4(2). – Pp. 114–117. 11. Merkulova T. V. Matematicheskie modeli v avtomatizatsii upravleniya zapasami / T. V. Merkulova, N. V. Akulov // Ekonomika: problemy teorii ta praktyku : zb. nauk. pr. – Dnipropetrovsk : DNU, 2007. – Vol. 232. – T. II. – Pp. 525–533. 12. Merkulova T. V. Ispolzovanye ABC-analiza v upravlenii zapasami / T. V. Merkulova, N. V. Akulov // Visnyk KhNU imeni V. N. Karazina. Ekonomichna seriia. – 2007. –

No. 786. – Pp. 140–143. 13. Merkulova T. V. Kriterii otsenki deyatel'nosti nalogovoy sluzhby v svete teorii agentskikh odnosheniy / T. V. Merkulova // Naukovi pratsi Donetskoho natsionalnoho tekhnichnoho universytetu. Seriya: ekonomichna. – Donetsk : DonNTU, 2008. – Vol. 34-2(138). – Pp. 174–178. 14. Rumiantssev N. V. Modelirovaniye gibkikh proizvodstvenno-logisticheskikh sistem / N. V. Rumiantssev. – Donetsk : Izd. Yugo-Vostok, 2004. – 235 p. 15. Rumiantssev M. V. Doslidzhennia systemy obsluhovuvannya z nenadiinym prykladom i perenaladzhenniam na pochatku periodu zainiatosti / M. V. Rumiantssev // Biznes Inform. – 2011. – No. 7. – Pp. 10–13. 16. Rumiantssev M. V. Hnuchki lohystichni systemy z perenaladzhenniam na pochatku periodu zainiatosti i vtratoi vymoh / M. V. Rumiantssev // Biznes Inform. – 2012. – No. 4. – Pp. 25–27. 17. Rumiantssev M. V. Hnuchki lohystichni systemy z perenaladzhenniam v kintsi periodu zainiatosti i vtratoi vymoh / M. V. Rumiantssev // Biznes Inform. – 2012. – No. 5. – Pp. 51–54. 18. Mnushko Z. M. Analiz napriamkiv doslidzhen z ekonomiky, menezhmentu ta marketynhu v farmatsii / Z. M. Mnushko // Visnyk farmatsii. – 2004. – No. 4. – Pp. 53–58. 19. Hromovyk B. P. Problemni pytannia lohystichnoho obsluhovuvannya spozhyvachiv likarskykh zasobiv / B. P. Hromovyk // Farmatsevtichnyi zhurnal. – 2007. – No. 5. – Pp. 14–18. 20. Pestun I. V. Marketynhove informatsiine zabezpechennia protsesu pryiniattia upravlynskykh rishen v farmatsii / I. V. Pestun, Z. M. Mnushko // Farmatsevtichnyi zhurnal. – 2007. – No. 1. – Pp. 9–14. 21. Tolochko V. M. Upravlinnia farmatsiieiu / V. M. Tolochko. – Kh. : Vyd. NFAU, 2004. – 386 p. 22. Dorokhova L. P. Model v menezhmenti. Farmatsevtichna entsyklopediia / L. P. Dorokhova. – K. : Morion, 2005. – Pp. 519–520. 23. Dovhan S. V. Matematychno modeliuвання v marketynhu / S. V. Dovhan. – Dnipropetrovsk : NHU, 2002. – 194 p. 24. Shennon R. Imitatsionnoye modelirovaniye sistem – iskusstvo i nauka / R. Shennon. – M. : Mir, 1978. – 301 p. 25. Modeling of two strategies in inventory control system with random lead time and demand / E. Kopytov, L. Greenglaz, A. Muravyov et al. // Computer Modeling and New Technologies. – 2007. – No. 1. – Pp. 21–30. 26. Moore J. Decision modeling with Microsoft Excel / J. Moore, L. Weatherford. – New Jersey : Prentice Hall, 2004. – 1 024 p.

Information about the author

Oleksandr Dorokhov – PhD in Engineering, Associate Professor of Information Systems Department of Kharkiv National University of Economics (9a Lenin Ave, 61166, Kharkiv, e-mail: aleks.dorokhov@meta.ua).

Інформація про автора

Дорохов Олександр Васильович – канд. техн. наук, доцент кафедри інформаційних систем Харківського національного економічного університету (61166, м. Харків, пр. Леніна, 9а, e-mail: aleks.dorokhov@meta.ua).

Информация об авторе

Дорохов Александр Васильевич – канд. техн. наук, доцент кафедры информационных систем Харьковского национального экономического университета (61166, г. Харьков, пр. Ленина, 9а, e-mail: aleks.dorokhov@meta.ua).

A double-blind peer review has been held.

Стаття надійшла до ред. 04.12.2012 р.